

Apr.1.2017 Copyright 2017 HIROSE ELECTRIC CO., LTD. All Rights Reserved.

COUNT	DESCRIPTION OF REVISIONS	BY	CHKD	DATE	COUNT	DESCRIPTION OF REVISIONS	BY	CHKD	DATE
△				..	△				..
△				..	△				..
△				..	△				..

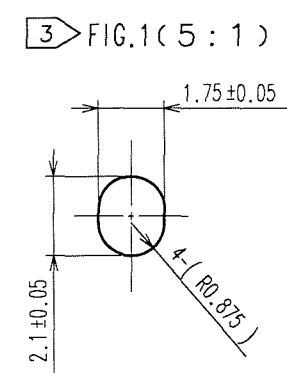
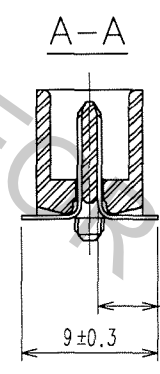
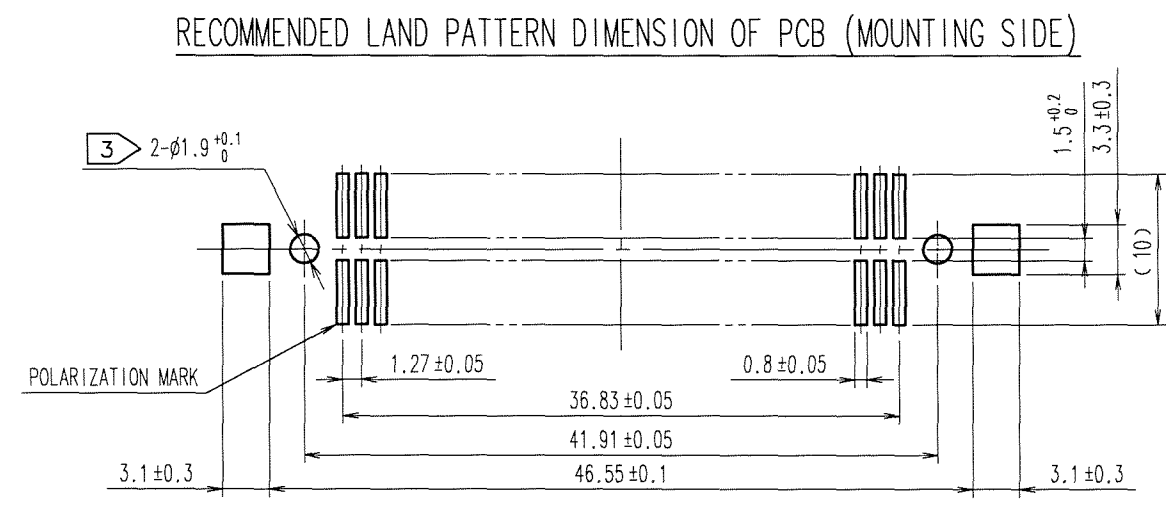
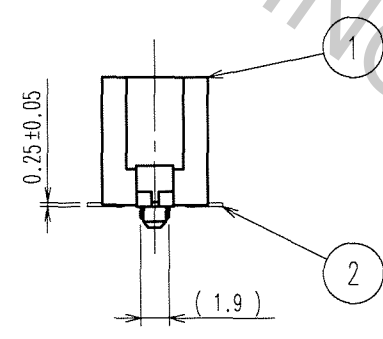
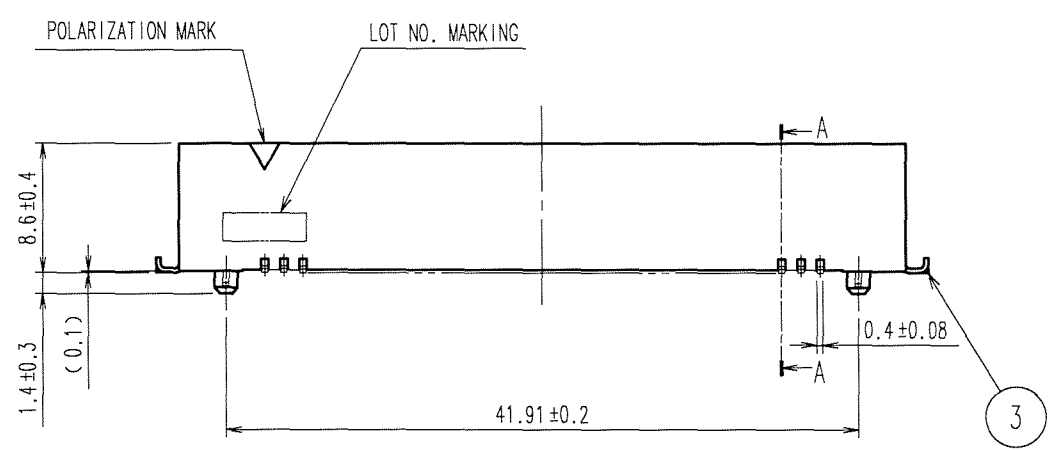
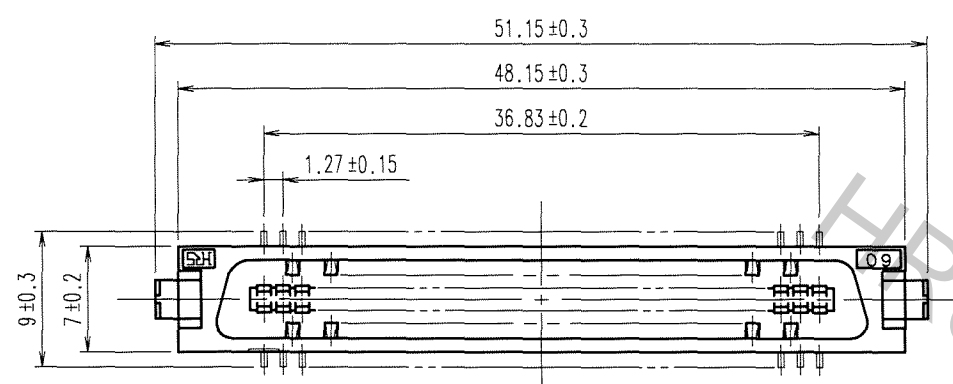

NOTES 1 LEAD CO-PLANARITY SHALL BE 0.15 MAX.  
 2 THE DIMENSIONS IN PARENTHESES ARE FOR REFERENCE.  
 3 IN CASE OF THE AUTOMATED MOUNTING, RECOMMENDED HOLE DIAMETER OF BOSS IS SHOWN IN FIG.1.

3	BRASS	TIN-PLATING	2	PHOSPHOR BRONZE	CONTACT AREA:GOLD 0.2μ m min.
1	PPS	LIGHT BROWN (UL94V-0)			LEAD AREA:TIN-PLATING 2μ m min.
					UNDER PLATING:NICKEL 2μ m min.
NO.	MATERIAL	FINISH, REMARKS	NO.	MATERIAL	FINISH, REMARKS

CODE NO. (OLD) CL	DRAWN A. SUZUKAWA 06.03.07	DESIGNED H. Nakamura 06.03.07	CHECKED K. Ogiwara 06.03.07	APPROVED H. Okawa 06.03.07	RELEASED ..
----------------------	----------------------------------	-------------------------------------	-----------------------------------	----------------------------------	----------------

SCALE 2 : 1	DRAWING NO. EDC3-082405-21	PART NO. FX2-60P-1.27SVL (71)
UNITS mm	HRS HIROSE ELECTRIC CO., LTD	CODE NO. CL572-2055-8-71

TO  
PCK

1/1