

THIS DRAWING IS UNPUBLISHED. RELEASED FOR PUBLICATION .19
 BY AMP INCORPORATED. ALL RIGHTS RESERVED.

LOC	DIST	REVISIONS			
P	LTR	DESCRIPTION	DATE	DWN	APVD
AF	50	D	RELEASED TO PROD. 063A-0167-00	15MAR00	MF KR

- 1 CONTINUOUS STRIP ON REELS WITH TERMINALS LOCATED ON 5.59±0.08 [.220±.003] CENTERS.
- 2 SLOT ACCEPTS 0.32-0.50mm [#28-#24] AWG COPPER MAGNET WIRE. 2 WIRES OF THE SAME SIZE PER SLOT.
- 3 BARREL TO ACCEPT 0.2-0.6mm² [#24-#20] AWG LEAD WIRE.

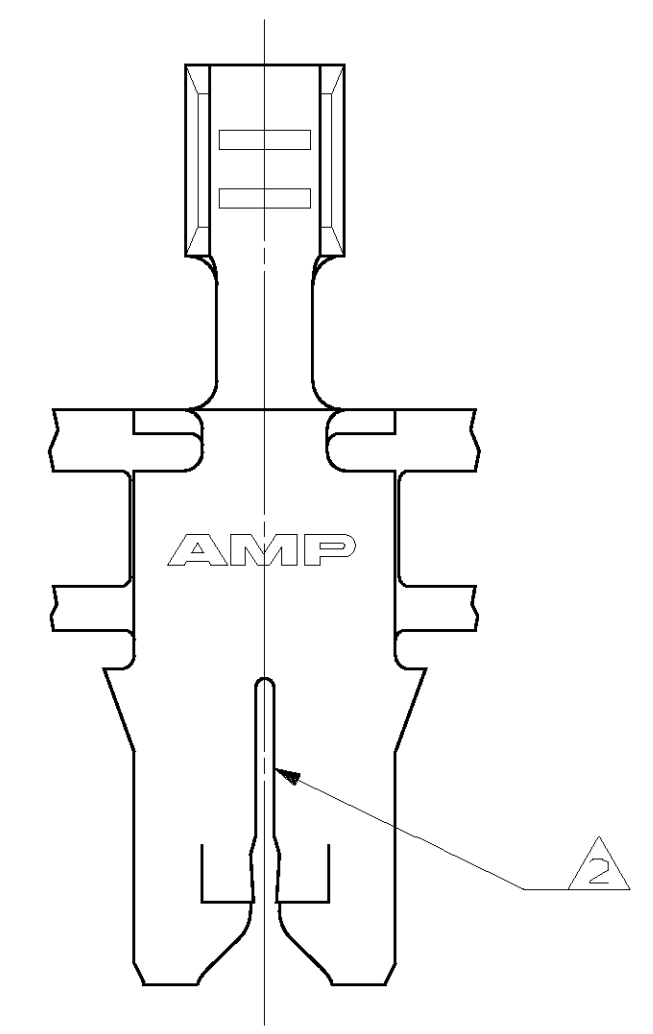
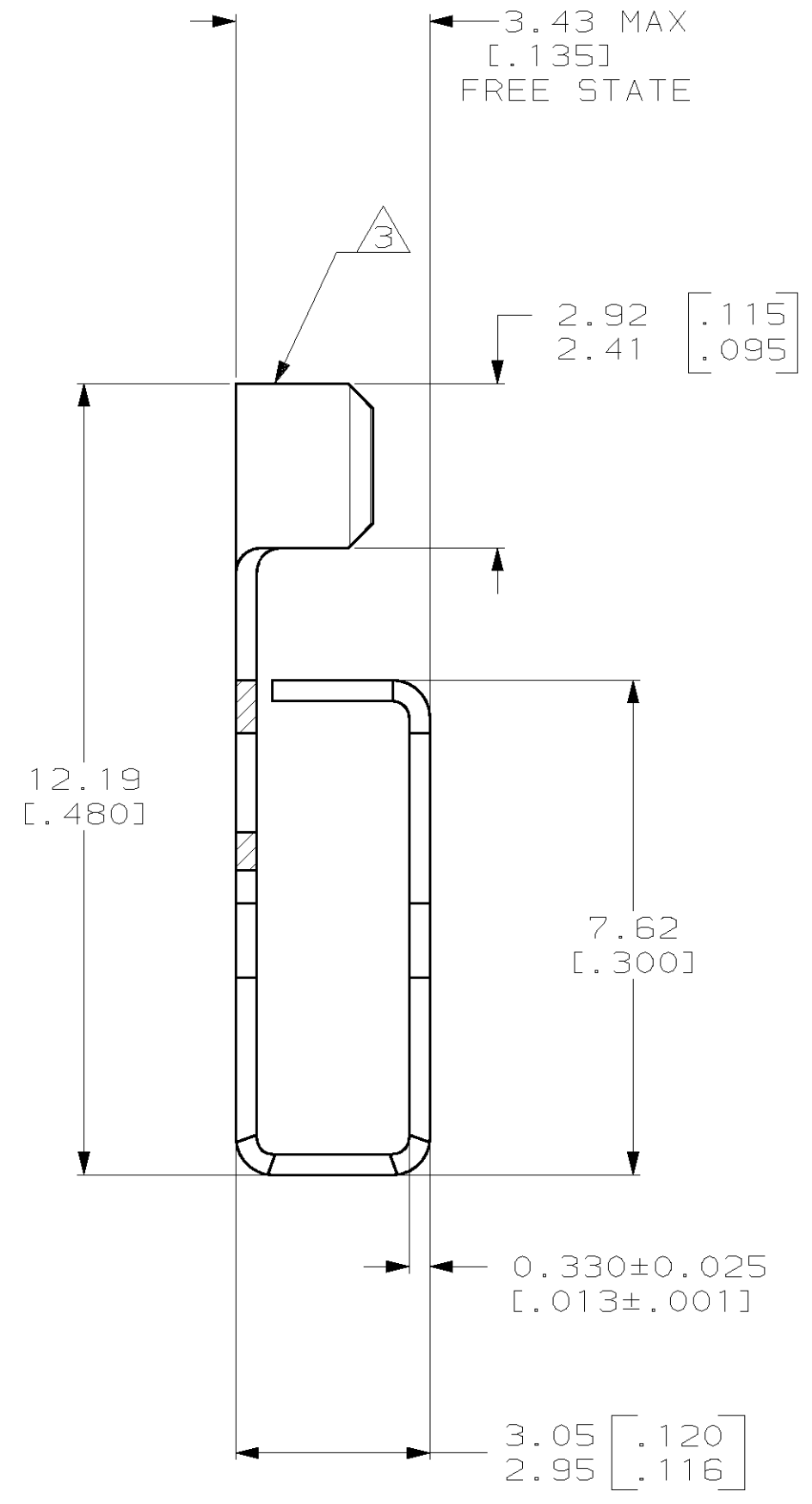
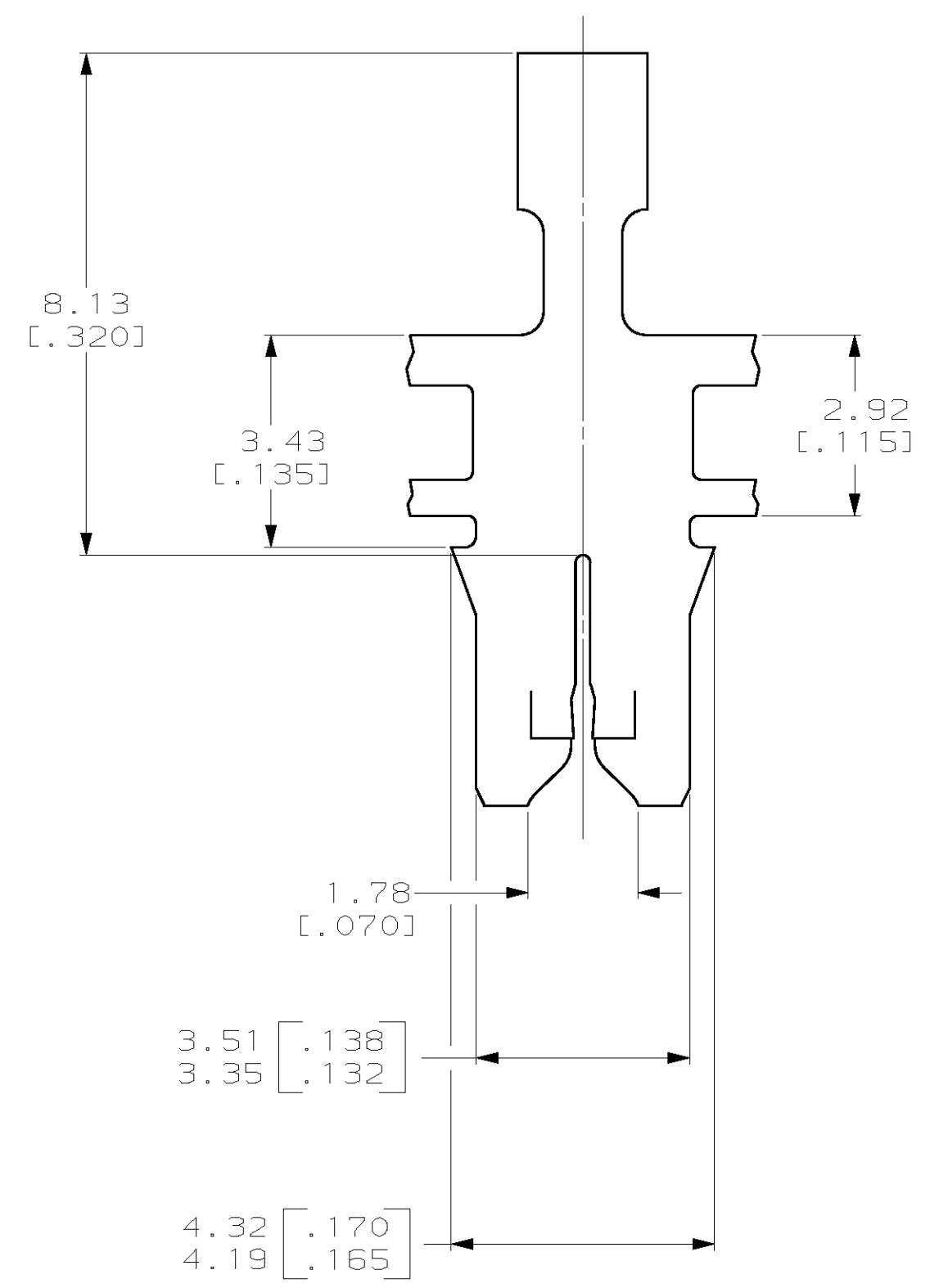
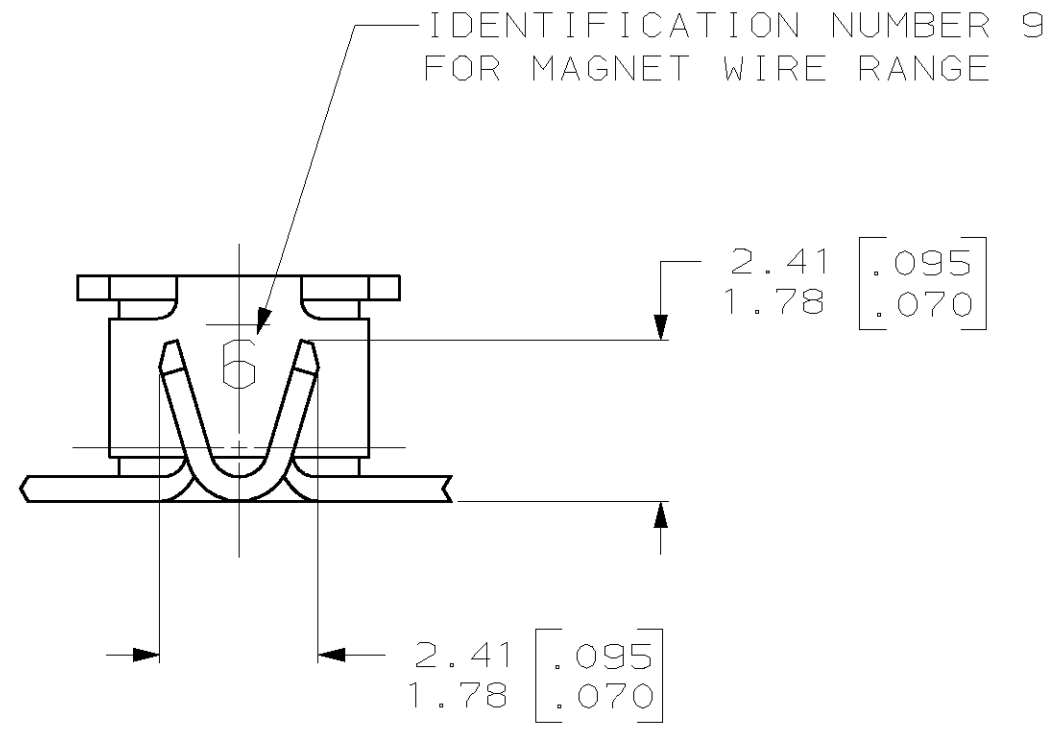

THIS DRAWING IS A CONTROLLED DOCUMENT.		DWN K.L.STONEROAD 09DEC99	63641-1 PART NO	
DIMENSIONS: mm [INCHES]		CHK M.S.FEHER 09DEC99	AMP Incorporated Harrisburg, PA 17105-3608	
TOLERANCES UNLESS OTHERWISE SPECIFIED:		APVD K.A.RANDOLPH 09DEC99	NAME TERMINAL, F-CRIMP 300 SERIES MAG-MATE™	
0 PLC ±- 1 PLC ±- 2 PLC ±0.25 [.010] 3 PLC ±- 4 PLC ±- ANGLES ±-		PRODUCT SPEC 108-2012	SIZE A2	CAGE CODE 00779
MATERIAL H04 BRASS		APPLICATION SPEC 114-2046	DRAWING NO C- 63641	RESTRICTED TO -
FINISH 0.002032 [.000080] MIN TIN		WEIGHT -	SCALE 10:1	SHEET 1 OF 1
		CUSTOMER DRAWING		REV D