

RN-42 Bluetooth Module (#30086)

The RN-42 Bluetooth Module provides a reliable low-cost method for wireless communication interface between two devices such as a microcontroller, PC, cell phone or another module. This module can pair up with devices supporting Bluetooth SPP (Serial Port Profile) to establish a serial interface. The RN-42 Bluetooth Module is breadboard friendly and is compatible with all 5 V and 3.3 V microcontroller platforms.

Features

- Fully qualified Bluetooth 2.1/2.0/1.2/1.1 module
- Low power
- Auto-discovery/pairing
- Auto-connect master mode
- Compatible with 5 V and 3.3 V microcontrollers
- LED indicators for status/connection
- 9600 default baud rate
- Jumper-select 115K baud rate or adjust to custom baud rate in software

Key Specifications

- Power Requirements: 5.0 VDC or 3.3 VDC @ ~5 mA sleep; ~15 mA idle; ~20 mA transmit; ~50 mA max
- Communication Interface: 5 V / 3.3 V asynchronous serial interface with RTS/CTS flow control, from 1200 bps to 921K bps
- Operating temperature: -40 to +185 °F (-40 to +85 °C)
- Dimensions: 2.33" x 1.16" x 0.45" in (59.18 x 29.46 x 11.43 mm)

Application Ideas

- Remote control a robot via PC, cell phone or another microcontroller
- Cable replacement (wireless serial interface)
- Measurement and monitoring systems
- Industrial sensors and controls



Quick-Start Circuit

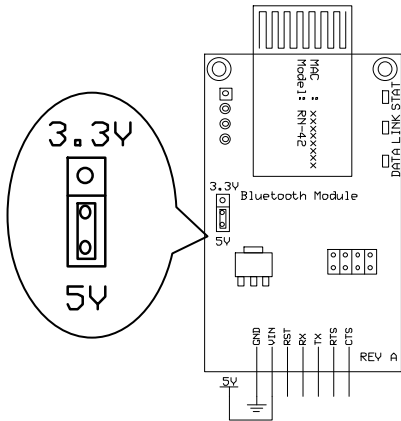

Figure 1: 5 V microcontroller

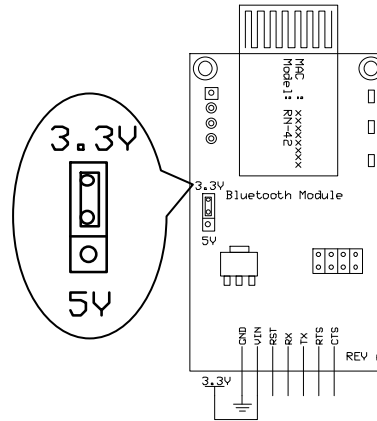

Figure 2: 3.3 V microcontroller

Set the module voltage to 5 V or 3.3 V to match your microcontroller system, using the voltage selection jumper as shown above. Connect VIN and GND as shown above, and then connect RX, TX, RTS and CTS to available I/O pins on your microcontroller. If you do not wish to use flow control you can connect RTS/CTS together instead.

Important Information

- BE SURE VOLTAGE JUMPER IS SET PROPERLY (5 V OR 3.3 V) BEFORE APPLYING POWER!
- Please see the RN-42 Advanced User Manual for complete command listing.
- The 4 unused pads in the top left corner are for factory firmware programming and are not useful to the end-user.

Specifications

Symbol	Quantity	Minimum	Typical	Maximum	Units
V_{IN}	Supply Voltage ¹	4.8	5V	5.2	V
V_{IN}	Supply Voltage ²	3.2	3.3	3.4	V
I_{VIN}	Supply Current ¹	5	15	50	mA
—	Operating Range ³	36	55	60	Feet

1. When supply voltage jumper is set to 5V
2. When supply voltage jumper is set to 3.3V
3. Approximate readings in office environment, throughput and range may vary depending on environmental conditions and RF interference

Pin Definitions and Ratings

Pin	Name	Type	Function
1	GND	G	Digital Ground
2	VIN	P	5V or 3.3V power input (must be regulated)
3	RST	I	Resets the device when brought to GND (0V)
4	RX	I	Receive data input to RN-42 UART
5	TX	O	Transmit data output from RN-42 UART
6	RTS	O	Ready To Send output from RN-42 UART
7	CTS	I	Clear To Send input to RN-42 UART

Pin Type: P = Power, G = Ground, I = Input, O = Output

Communication Protocol

The RN-42 Bluetooth Module communicates using asynchronous serial and supporting RTS/CTS flow control. If you do not wish to use hardware flow control or your device does not support it you may tie the RTS and CTS lines together on the RN-42 Bluetooth Module.

Command Set

The RN-42 Bluetooth Module command set is similar to the industry standard Hayes AT protocol. For a complete command reference supported by this module please see the RN-42 Advanced User Manual which can be downloaded as a PDF file from the RN-42 Bluetooth Module product page.

Configuration Jumpers

The RN-42 Bluetooth Module has four sets of configuration headers as shown below. Note the order of the jumpers. Two shorting (shunt) blocks are included to allow enabling different features of the RN-42 Bluetooth Module. The extra shorting block is hanging off one pin on an unused jumper.

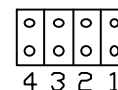

Default Baud Rate (4)

OFF = 115K default; can be overridden by software baud rate configuration commands
ON = 9600; ignores software baud rate configuration. Default setting is ON.

Auto Master (3)

ON = Device acts as a Bluetooth master, auto-connecting to a stored remote address. First you must set the address of the slave device using the SR command or through instant cable replacement settings. Default setting is OFF.

Auto Discovery (2)

In slave mode, sets a special class of device that is used by the master to auto connect. If jumper 3 is also ON, the device performs a search, stores and connects to a remote slave which also has jumper 2 ON. Default setting is OFF.

Factory Reset (1)

Set this jumper ON, power up unit, then toggle the jumper from ON to OFF three (3) times to return the unit to factory settings. Default setting is OFF.

LED Indicators

The RN-42 Bluetooth Module has three LED indicators which give feedback to the user. The functions of these LEDs are as follows:

Green LED (STAT)

This LED's blink rate indicates device status :

- 10 x per second = In configuration mode
- 2 x per second = Boot up, remote configurable
- 1 x per second = Discoverable/Idle
- On Solid = Connected

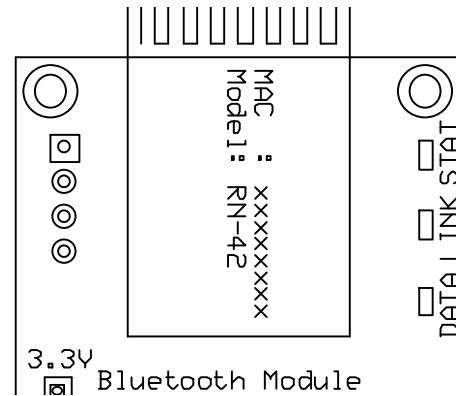

Note: When performing a factory reset the green LED flickers at power-up and once again at the end of the reset sequence. This helps indicate the module was successfully reset. See the previous section on configuration jumpers for more information.

Blue LED (LINK)

When lit, this LED indicates that the RN-42 Bluetooth module has established a communication connection with the remote device.

Red LED (DATA)

Blinking 1 time per second = Data over the UART. This LED only functions during the remote configuration timer window. What this means is that once the module goes into fast data mode and cannot be remotely configured the LED will stop blinking.

Pairing/Connecting

When pairing the RN-42 with another device such as a laptop or cell phone the default passkey is "1234". The device is discovered as RN42-xxxx (where xxxx is the last 4 digits of the device MAC address). On a PC with Bluetooth the device will have a COM port assigned to it. When this COM port is opened the PC should reconnect to the module (the Blue LED should light up). At this point you can send/receive serial data.

Connecting via Bluetooth from a PC may vary with different computers and version of the operating system, however there should be a method to add the device and assign a COM port to it. When given the option you should always choose to use the pairing code so that in future connections it does not prompt you for the code.

When connecting from module to module using two microcontrollers, jumper 1 is ON to force the baud rate to 9600 bps. If you set the software baud rate you won't need to set jumper 1 to ON. This will free up both jumpers for one of two auto-connect modes.

Auto-Master

Place a shunt on jumper 3 to make the device acts as a Bluetooth Master, auto-connecting to a stored remote address. First you must set the address of the remote (slave) device using the SR command or through instant cable replacement settings. See the RN-42 Advanced User Manual for more information.

Auto-Discovery

Place shunts on jumpers 2 and 3 to configure the device as a master module. At power-up a master module will search and attempt to connect to another (remote) RN-42 Bluetooth Module which has jumper 3 ON. See the section on configuration jumpers for more information.

Troubleshooting

- Always be sure of your power source. You should have a regulated 5V or 3.3V source and the power supply selection jumper must be in the correct position.
- If you're having trouble with communication be sure your baud rate is set correctly.
- Be sure your microcontroller TX pin connects to the RN-42 Bluetooth Module RX pin. Your RX pin should connect to the TX pin on the module. (Not TX to TX or RX to RX)
- If you cannot connect using the Auto-Master mode (using the stored remote address) try the Auto-Discovery Mode. This could indicate the remote address is not set properly.
- Check your jumper settings. Remember, the jumpers are 1 through 4 from right to left, not left to right as you might expect.
- When connecting from a PC, be sure to select the correct COM port. Sometimes windows will assign more than one port to the Bluetooth device. The one to use is the one in the properties of the device in the Bluetooth device window. Select to show Bluetooth devices, right-click on your device and select properties. One of the tabs should list the assigned COM port. This varies depending on PC make and operating system.
- When having communication issues try disconnecting, cycling power on the module and reconnecting. This can happen when you have just paired with a PC in some cases.
- Try a factory reset. See the section on configuration jumpers for more information.

Module Dimensions

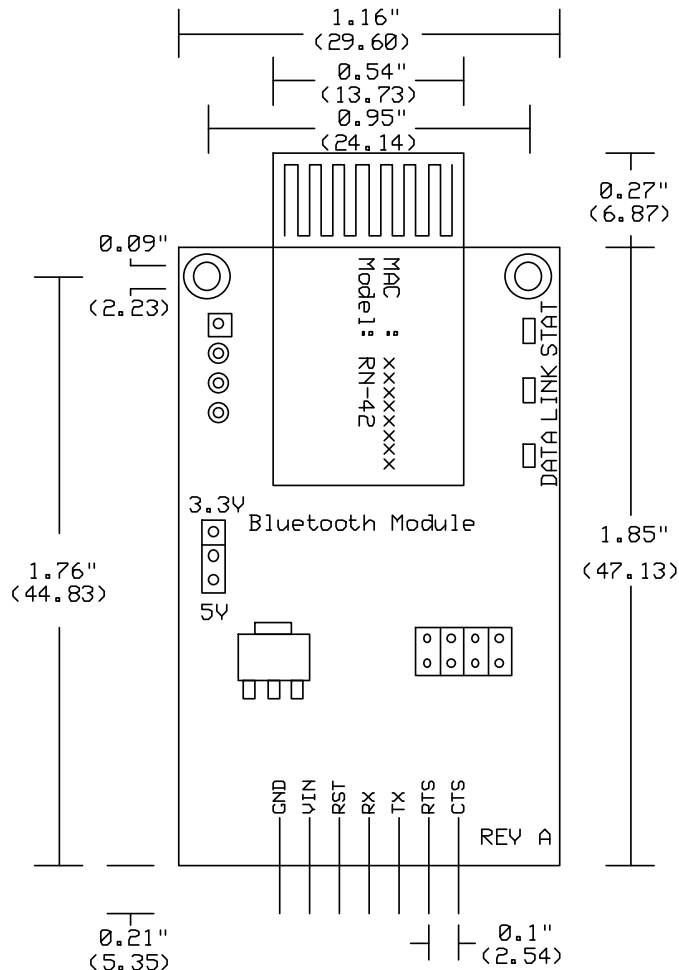

BASIC Stamp® Example Code

This program uses the Debug Terminal, which is built into the BASIC Stamp Editor software. The software is a free download from www.parallax.com/basicstampsoftware. Before downloading this program be sure to make the connections specified in the code and make sure the voltage selection jumper is in the 5V position.

Once this program has been run successfully you can remove the shorting block (shunt) from jumper 1 and the module will communicate at 9600 bps. If you prefer to set the module to communicate at 2400bps you can change the command "SU,96" to "SU,24".

```
' RN-42 Set Baud Rate.bs2
' Sets the default baud rate to 9600bps

' {$STAMP BS2}
' {$PBASIC 2.5}

Reset          PIN      0          ' To RN-42 RST pin
TX             PIN      1          ' To RN-42 RX pin
RX             PIN      2          ' To RN-42 TX pin
CTS            PIN      3          ' To RN-42 RTS pin
RTS            PIN      4          ' To RN-42 CTS pin

Baud           CON      84          ' 9600bps on BS2

response       VAR      Byte(10)    ' Buffer

InitIO:
  HIGH TX      ' Initialize TX line
  PAUSE 100    ' Allow time to settle

Main:
  PAUSE 2000   ' Allow hardware to be ready
  SEROUT TX\CTS, 84, ["$$$"] ' Set Command Mode
  PAUSE 500   ' Allow time for Command Mode
  SEROUT TX\CTS, 84, ["SU,96", CR, LF] ' Change Baud Rate to 9600
  SERIN RX\RTS, 84, [STR response\10\13] ' Buffer response
  IF response(0) = "A" THEN ' Check for AOK
    IF response(1) = "O" THEN
      IF response(2) = "K" THEN
        DEBUG CLS, "SUCCESS!", CR ' Command executed successfully
      ENDIF
    ENDIF
  ELSE
    DEBUG CLS, "FAILURE!", CR ' Command failed
  ENDIF
END
```

Resources and Downloads

To check for the latest version of this document, free software, application notes and example programs from the RN-42 Bluetooth Module product page, go to www.parallax.com and search 30086.