

# DEMOMMA8491 Xtrinsic Accelerometer Evaluation Kit

by: FengYi Li  
Applications Engineer

This application note provides an overview of the Xtrinsic DEMOMMA8491 kit and its evaluation guidelines.

The DEMOMMA8491 kit contains two boards:

- **Demo board:** provides a tamper detection sensor demonstration using the Xtrinsic MMA8491Q 45° tilt sensor and 3-axis accelerometer, housed in a transparent plastic case.
- **Breakout board:** provides easy access to every pin of the QFN sensor for evaluation.

This document describes board functionality and features, how to use these boards, and what to look for when evaluating the devices. The last section provides reference schematics and the bills of materials.

## Contents

1	DEMOMMA8491 Demo Board	2
1.1	Acceleration directions	2
1.2	Using the demo board	2
1.3	Acceleration values are cumulative	3
2	DEMOMMA8491 Breakout Board	4
2.1	Pin map	4
2.2	Suggested application connections	5
2.3	Soldering considerations	5
2.4	Evaluating performance	6
3	Schematics and Bill of Materials (BOM)	6
3.1	Demo board schematic	6
3.2	Demo board BOM	6
3.3	Breakout board schematic	7
3.4	Breakout board BOM	7
4	Revision History	8

# 1 DEMOMMA8491 Demo Board

The demo board of the DEMOMMA8491 kit is an out-of-the-box 3-axis MEMS tilt sensor. It showcases a simple tilt sensor implemented with the MMA8491Q device, with 10 additional passive components.

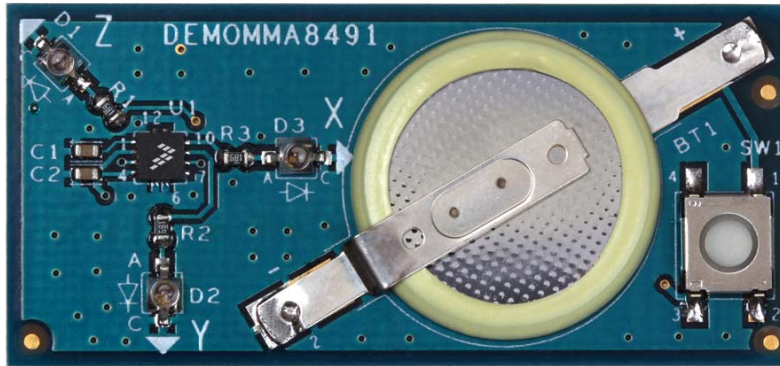

Figure 1. DEMOMMA8491 demo board

## 1.1 Acceleration directions

The demo board uses the acceleration directions in Figure 2. The left image shows the acceleration direction on the MMA8491Q device. The right image shows the acceleration direction of the demo board.

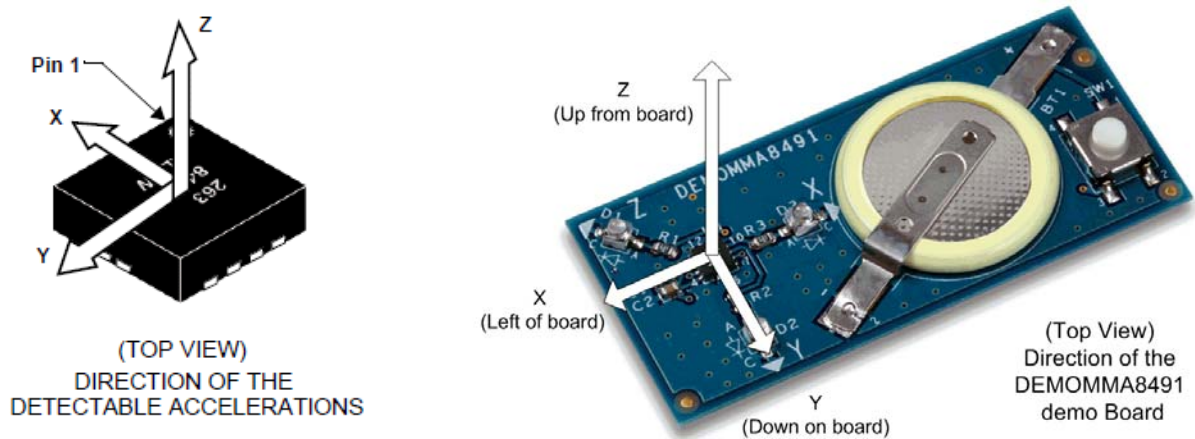

Figure 2. Sensor orientation

## 1.2 Using the demo board

The demo is powered by a 3V coin battery and is controlled by one switch button (SW1). When the switch is pressed, the tilt sensor is powered on, and it takes one sample of the current acceleration. The tilt detection result is simultaneously displayed with 3 LEDs (each LED is paired with one of the X, Y, Z axes). A lit LED indicates that a tilt angle *greater than or equal to* 45° is detected on that axis.

To demonstrate the kit, hold the demo board to the desired position, then press and hold down the switch button. Make sure that your hand is steady. Observe the LEDs for a tilt report. Release the button to discard the sample.

Figure 3 shows the LED status at 6 different orientations.

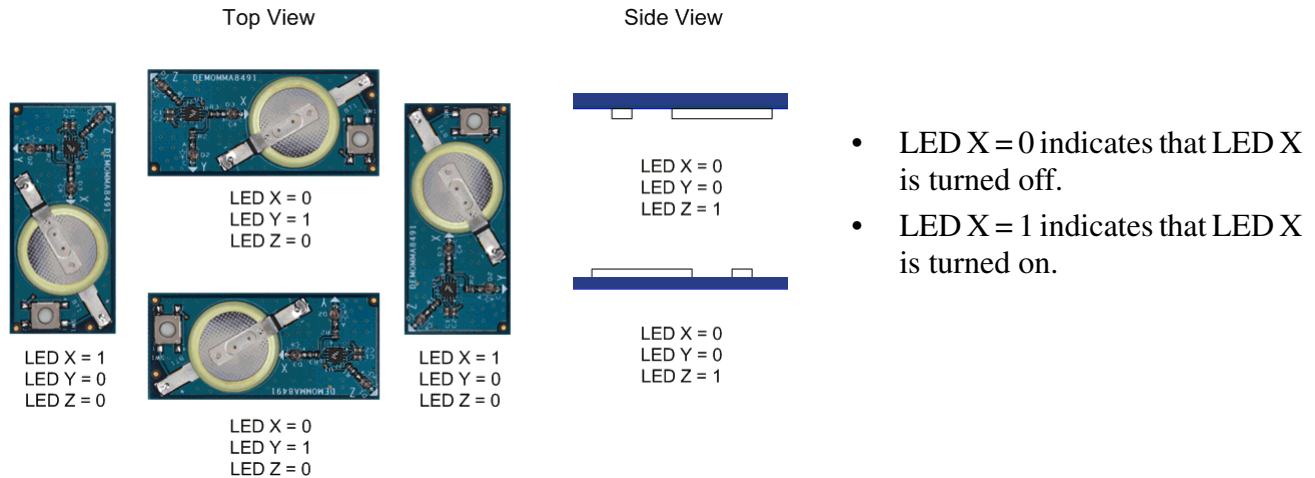

Figure 3. LED states for different orientations

### 1.3 Acceleration values are cumulative

The MMA8491Q device is a MEMS-based accelerometer. It picks up the acceleration signal (if it is present), and compares the acceleration to an internal threshold of 0.688g. When the demo board is held at a 45° angle, the acceleration reading along that axis (coming from the earth gravity) is about 0.688g. In this case, that axis's output (XOUT, YOUT or ZOUT) is triggered to logic high.

When you provide external acceleration (other than the earth gravity) on the demo board, the tilt sensor reports the cumulative acceleration. As the result of these additional g-forces, you might observe positive tilt detection when the board is at a position less than a 45° angle.

## 2 DEMOMMA8491 Breakout Board

For evaluating the MMA8491Q industrial 12-pin QFN tilt sensor, the breakout board provides practical and efficient access, with minimum soldering work.

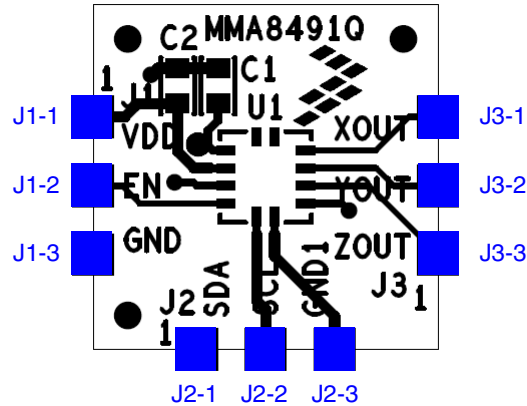

Figure 4. Breakout board

The DEMOMMA8491 breakout board has fanned out all of the MMA8491Q pins, except the bypass pin (BYP). It has three top-layer components: the MMA8491Q device and two 0.1 uF ceramic capacitors (C1, C2). The board itself is a two-layer PCB, using a 0.1 inch pitch between the breakout pins.

The device should have a 0.1 uF capacitor connected between the bypass pin (BYP) and ground. This requirement is satisfied with the capacitor C1. The device also needs a high frequency filter capacitor on VDD. This requirement is satisfied with the capacitor C2. These recommendations are listed in the MMA8491Q data sheet.

### 2.1 Pin map

Table 1 maps the pins of the breakout board to the MMA8491Q device pins.

Table 1. Breakout board to MMA8491Q sensor pins

Breakout Board		MMA8491Q Device		Description	Pin Status
Pin	Name	Pin	Name		
J1-1	VDD	2	Vdd	Supply Voltage	Input
J1-2	EN	4	En	Enable Accelerometer on logic 1	Input
J1-3	GND	7	Gnd	Ground plate	Ground
J2-1	SDA	4	SDA	I <sup>2</sup> C bus data	Ground
J2-2	SCL	5	SCL	I <sup>2</sup> C bus clock	Input
J2-3	GND	6	Gnd	Ground	Input / Output
J3-1	ZOUT	8	Zout	Tri-state Z-Axis tilt detect output	Output

**Table 1. Breakout board to MMA8491Q sensor pins (Continued)**

Breakout Board		MMA8491Q Device		Description	Pin Status
Pin	Name	Pin	Name		
J3-2	YOUT	9	Yout	Tri-state Y-Axis tilt detect output	Output
J3-3	XOUT	10	Xout	Tri-state X-Axis tilt detect output	Output

## 2.2 Suggested application connections

To ensure that the accelerometer is fully functional, connect the breakout board as shown in [Figure 5](#).

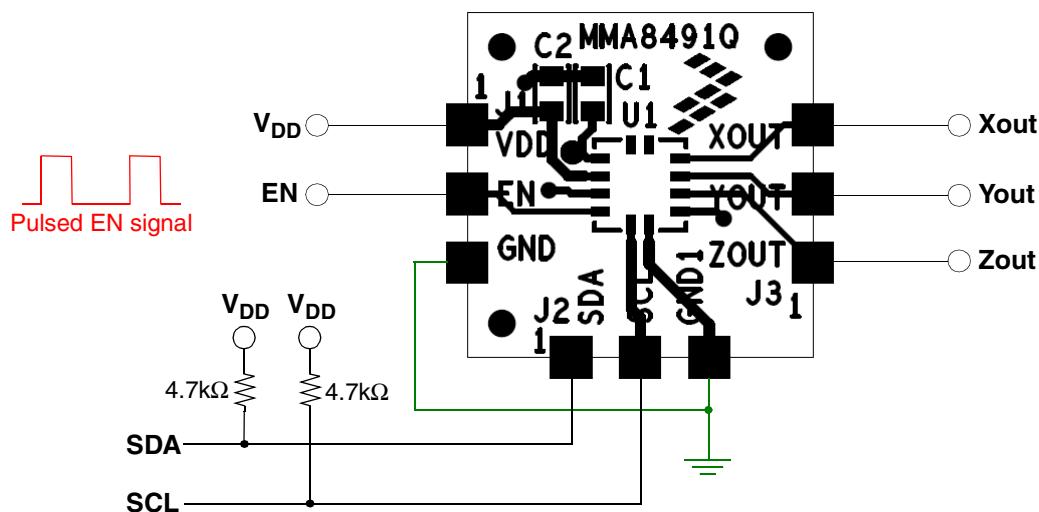

**Figure 5. Example application with I<sup>2</sup>C bus engaged**

This connection follows the recommendations listed in MMA8491Q data sheet.

- The power supply decoupling capacitor is placed as close as possible to the VDD pin. The 0.1 μF capacitor value has been chosen to minimize the average current consumption, while still maintaining an acceptable level of power supply high-frequency filtering.
- When the I<sup>2</sup>C communication line is used, pullup resistors (one pullup resistor for each line) should be used to connect to SDA and SCL. If the SDA/SCL pins are not used, then they should be tied to ground. It is recommended that you use resistors no less than 1KΩ, to reduce the current load on the I<sup>2</sup>C bus.

## 2.3 Soldering considerations

The breakout board is a top component two-layer PCB board, with device pins fanned out to 0.1 inch pitch copper pads. There is no special soldering handling requirement when using the breakout board—you can directly hand-solder wires to it.

For more information about the standard MMA8491Q device mounting process, see the MMA8491Q data sheet.

## 2.4 Evaluating performance

When evaluating the MMA8491Q tilt sensor performance using the breakout board, consider offset factors:

- Offset variation over temperature
- Board mount offset
- Breakout-board-to-system alignment

For offset variation and board mount offset data, see the MMA81941Q data sheet.

We suggest that you perform a breakout-board-to-system alignment check. Typically, the tilt sensor axes may not *exactly* align with the axes of the customer's system. This misalignment translates to the cross-axis offset, effectively changing the tilt detection angle. A system adjustment helps to get a more accurate evaluation result. You can use the readouts from the MMA8491Q device via I<sup>2</sup>C bus for a coarse alignment check, without having to use a reference accelerometer.

## 3 Schematics and Bill of Materials (BOM)

### 3.1 Demo board schematic

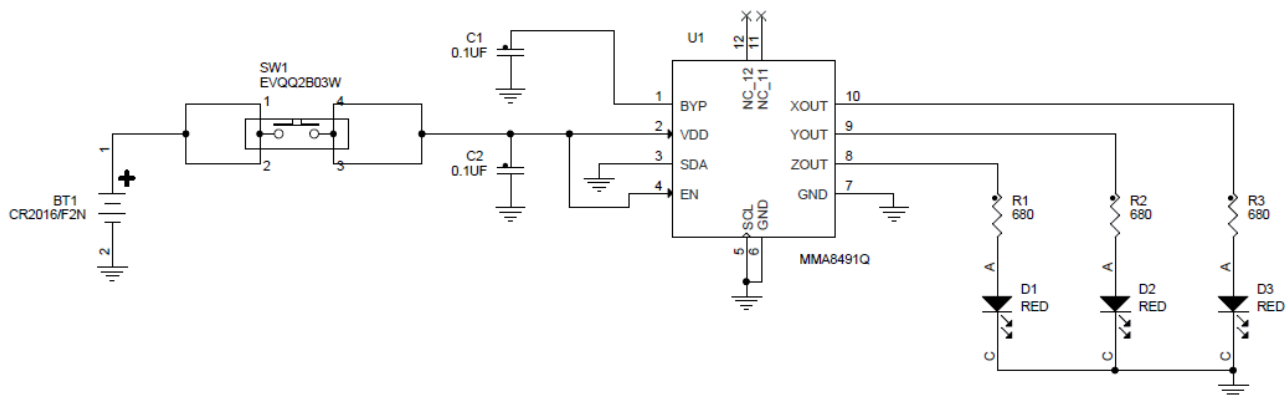

Figure 6. Demo board schematic

### 3.2 Demo board BOM

Table 2. Demo board BOM

Item	Quantity	Reference	Value	Description
1	1	BT1	CR2016-F2N	Battery, lithium coin, 3V 90MAH 20MM PCB SMT
2	2	C1, C2	GRM188R71H104KA93D	Capacitor, ceramic, 0.1UF 50V 10% X7R 0603
3	3	D1, D2, D3	HLMP-Q156-H0011	LED, RED SGL 50MA SMT
4	3	R1, R2, R3	RK73H1JTTD6800F	Resistor, MF 680 OHM 1/10W 1% 0603

**Table 2. Demo board BOM (Continued)**

Item	Quantity	Reference	Value	Description
5	1	SW1	EVQQ2B03W	Switch SPST, PB NO 0.5N 20MA 15V SMT
6	1	U1	MMA8491Q	IC, 3-axis low voltage tilt sensor 1.95–3.6V QFN12

### 3.3 Breakout board schematic

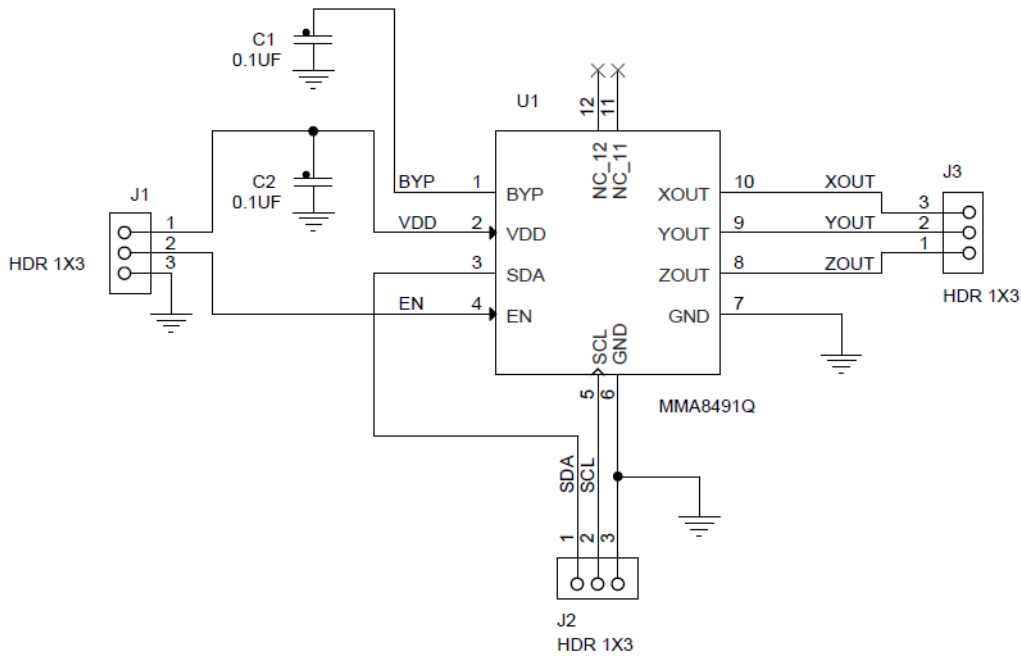

**Figure 7. Breakout board schematic**

### 3.4 Breakout board BOM

**Table 3. Breakout board BOM**

Item	Quantity	Reference	Value	Description
1	1	U1	MMA8491Q	IC, 3-axis low voltage tilt sensor 1.95–3.6V QFN12
2	2	C1,C2	GRM188R71H104KA93D	Capacitor, ceramic, 0.1uF 50V 10% X7R 0603

## 4 Revision History

Revision 0 is the initial release of this document.



**How to Reach Us:**

**Home Page:**

[freescale.com](http://freescale.com)

**Web Support:**

[freescale.com/support](http://freescale.com/support)

Information in this document is provided solely to enable system and software implementers to use Freescale products. There are no express or implied copyright licenses granted hereunder to design or fabricate any integrated circuits based on the information in this document.

Freescale reserves the right to make changes without further notice to any products herein. Freescale makes no warranty, representation, or guarantee regarding the suitability of its products for any particular purpose, nor does Freescale assume any liability arising out of the application or use of any product or circuit, and specifically disclaims any and all liability, including without limitation consequential or incidental damages. "Typical" parameters that may be provided in Freescale data sheets and/or specifications can and do vary in different applications, and actual performance may vary over time. All operating parameters, including "typicals," must be validated for each customer application by customer's technical experts. Freescale does not convey any license under its patent rights nor the rights of others. Freescale sells products pursuant to standard terms and conditions of sale, which can be found at the following address: [freescale.com/salestermsandconditions](http://freescale.com/salestermsandconditions).

Freescale, the Freescale logo, Altivec, C-5, CodeTest, CodeWarrior, ColdFire, C-Ware, Energy Efficient Solutions logo, Kinetis, mobileGT, PowerQUICC, Processor Expert, QorIQ, Qorivva, StarCore, Symphony, and VortiQa are trademarks of Freescale Semiconductor, Inc., Reg. U.S. Pat. & Tm. Off. Airfast, BeeKit, BeeStack, ColdFire+, CoreNet, Flexis, MagniV, MXC, Platform in a Package, QorIQ Qonverge, QUICC Engine, Ready Play, SafeAssure, SMARTMOS, TurboLink, Vybrid, and Xtrinsic are trademarks of Freescale Semiconductor, Inc. All other product or service names are the property of their respective owners.

© 2012 Freescale Semiconductor, Inc.